

**Intelligent Hybrid System**



**Single Line Telephone  
User Guide**

# Before using Your Telephone...

**Thank you for purchasing the NEC “Xen Topaz” telephone system.**

Due to the flexibility built into the system, your **Dialling Codes and Feature Capacities** may differ from those in this guide. Check with your NEC Authorised Supplier / System Administrator and make a note of any differences.

# Using Your Telephone

The NEC AT-21 Single Line Telephone is displayed here. This User Guide describes general analogue Single Line Telephone (SLT) procedures. Refer to the User Guide included with your specific SLT for details on additional key functions.

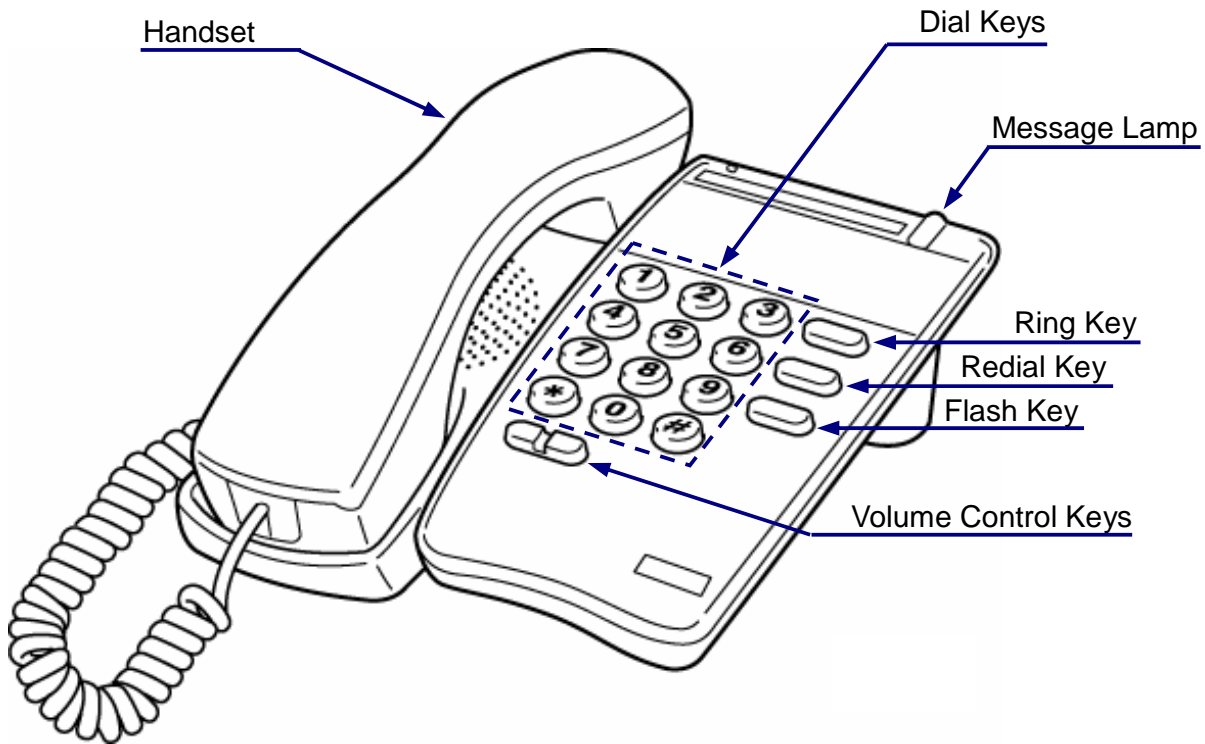

# Placing Calls

## Placing an Outside Call

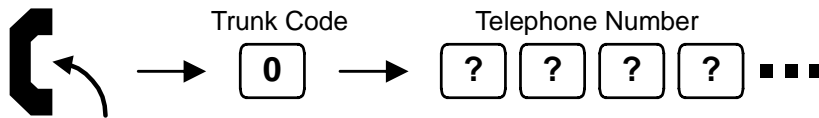

- ◆ Listen for Dial Tone before dialling the Telephone Number.

## Placing an Intercom Call

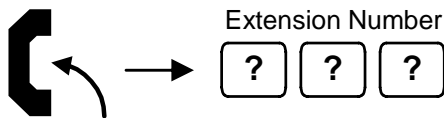

- ◆ Your call will ring or voice-announce. If you hear ringing, wait for an answer. If you hear a beep, begin speaking. Dialling "1" changes voice/ring mode (where the destination is a Topaz Telephone).

# Placing Calls Quickly

## Abbreviated Dialling <for outside calls>

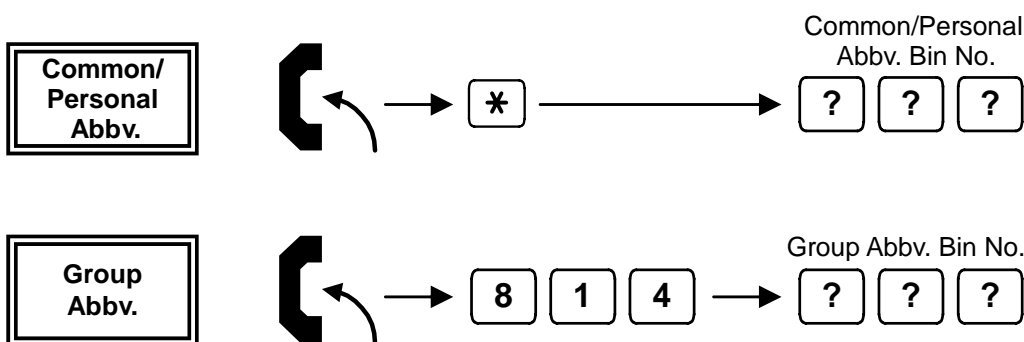

- ◆ Common/Personal Abbreviated Dialling Bins are numbered as follows (by default):  
2-digit dialling: Common = 00-79, Personal = 80-99, or  
3-digit dialling: Common = 000-899, Personal = 990-919.
- ◆ Single Line Telephones cannot store a number into an Abbreviated Dialling Bin. For this you must use a Display Topaz Telephone or PC Programming application. Ask your NEC Authorised Supplier for details.
- ◆ System programming is required to provide Group Abbreviated Dialling. Ask your NEC Authorised Supplier for details.

# Placing Calls Quickly

## Last Number Redial <for outside and intercom calls>

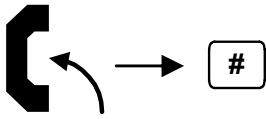

- ◆ *Intercom numbers can also be stored under Last Number Redial. (System programming is required. Ask your NEC Authorised Supplier for details.)*

# If your call doesn't go through...

## Setting Camp On / Callback / Trunk Queuing

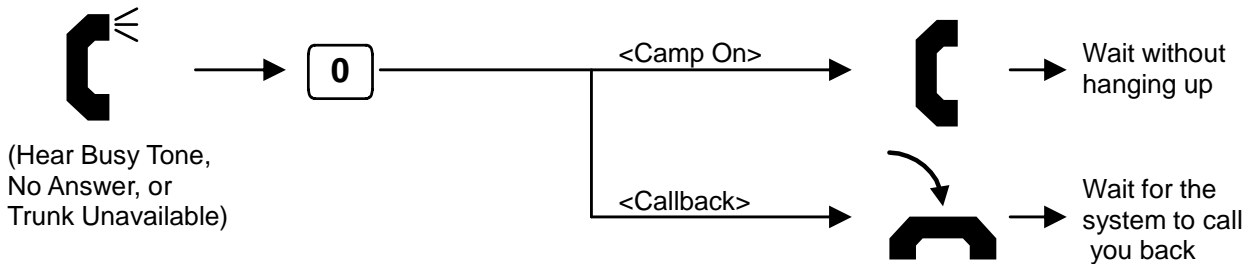

- ◆ **<Camp On>** *For Intercom Call, when you hear ringing, wait for the called party to answer.  
For Trunk Queuing, when you hear Dial Tone, begin dialling the telephone number.*
- ◆ **<Callback>** *For Intercom Call, when your phone starts the ringing, lift handset and wait for the called party to answer.  
For Trunk Queuing, when your phone starts the ringing, lift handset, hear Dial Tone and begin dialling the telephone number.*

## Cancelling Camp On / Callback / Trunk Queuing

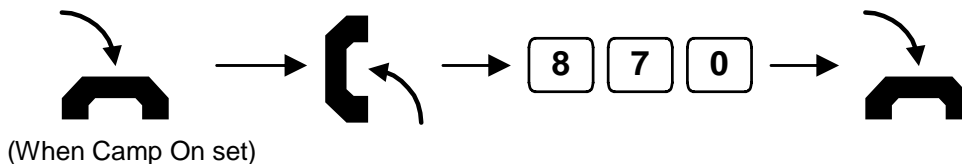

# If your call doesn't go through...

## Setting / Answering a Message Waiting Indication

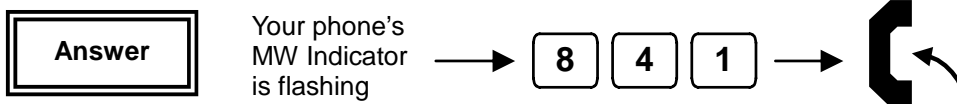
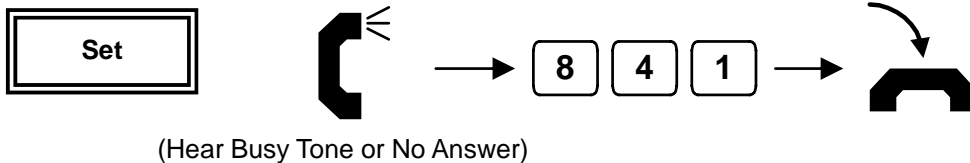

- ◆ When you set MW, the called party's MW Indicator starts to flash.
- ◆ When you answer MW, the MW Indicator shall automatically go off when the called party answers.

## Cancelling a Message Waiting Indication (at originating extension)

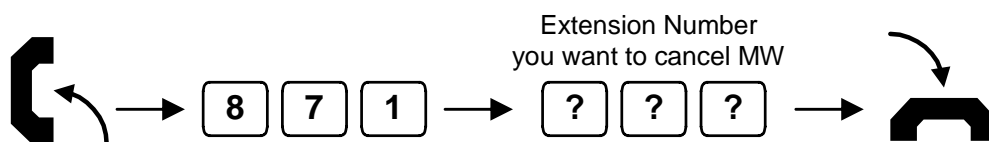

## Clearing All Message Waiting Indications (at any extension)

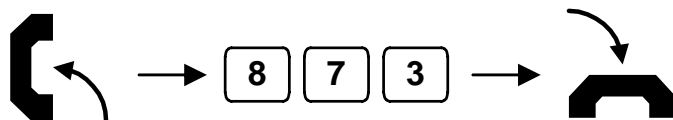

- ◆ Clear all messages (you have left for other extensions and messages other extensions have left for you).

# Answering Calls

## Answering an Outside / Intercom Call

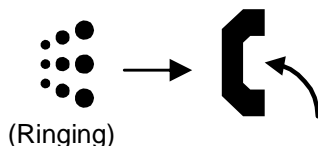

- ◆ Each type of incoming call can have its own distinctive ringing pattern. Ask your NEC Authorised Supplier for details.

# Answering Calls

## Picking up another Extension's Call

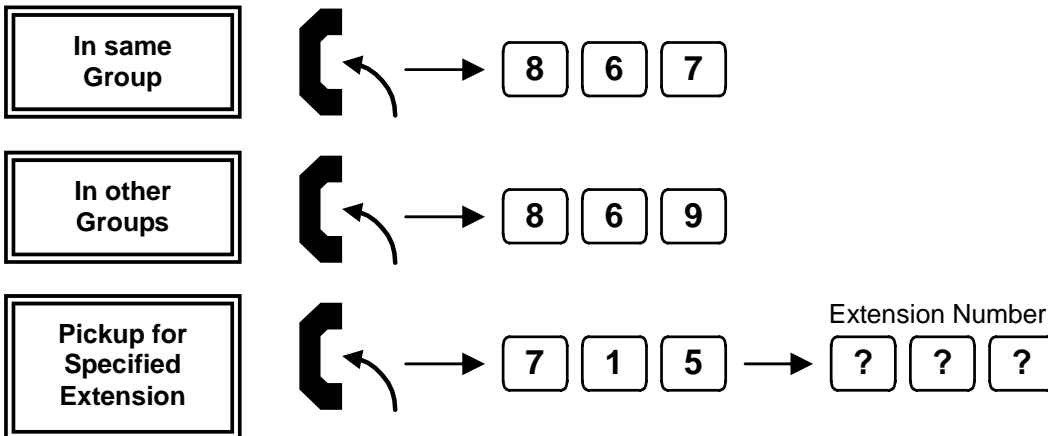

◆ System programming is required to allow Group Call Pickup. Ask your NEC Authorised Supplier for details.

# Hold / Transferring Calls

## Placing a Call on Hold / Retrieving a Held Call

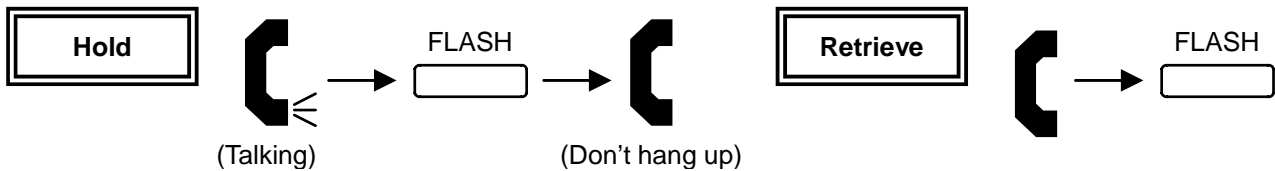

- ◆ If you go on hook, the held call will ring back.
- ◆ This operation puts your call on Exclusive Hold. Other extension users can not take the call off Hold.

## Retrieving a Held Outside Call

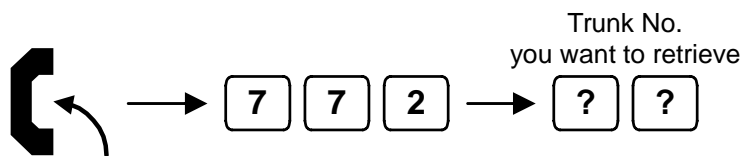

## Transferring a Call to another Extension

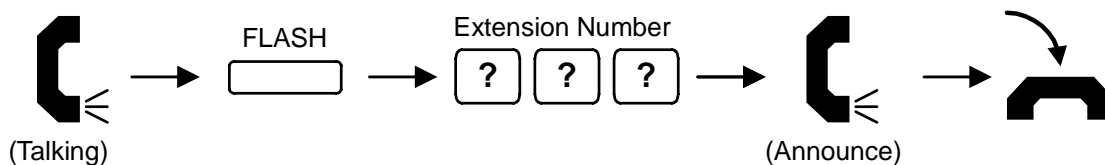

# Forwarding Calls / Do Not Disturb

## Do Not Disturb (DND)

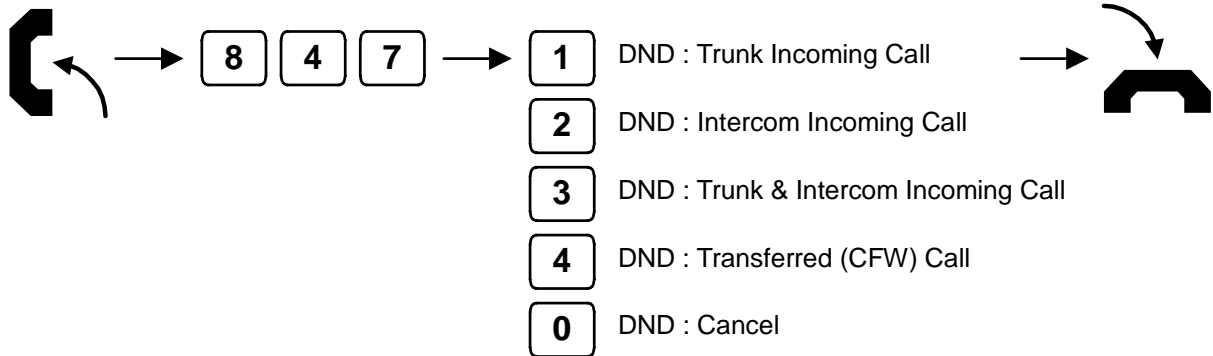

◆ When you set DND, the Internal Dial Tone pattern changes.

## Call Forwarding / Follow Me

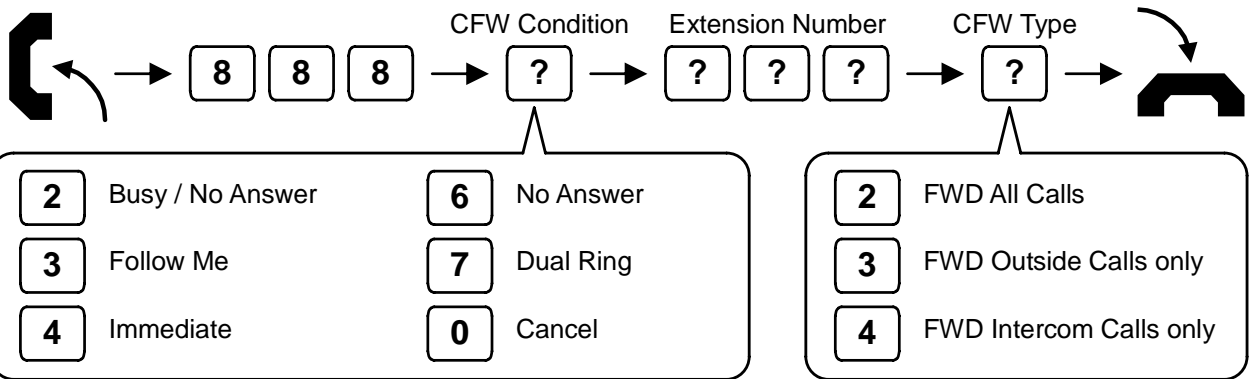

◆ When you set a Call Forward, the Internal Dial Tone pattern changes.

## Call Forward Off-Premise

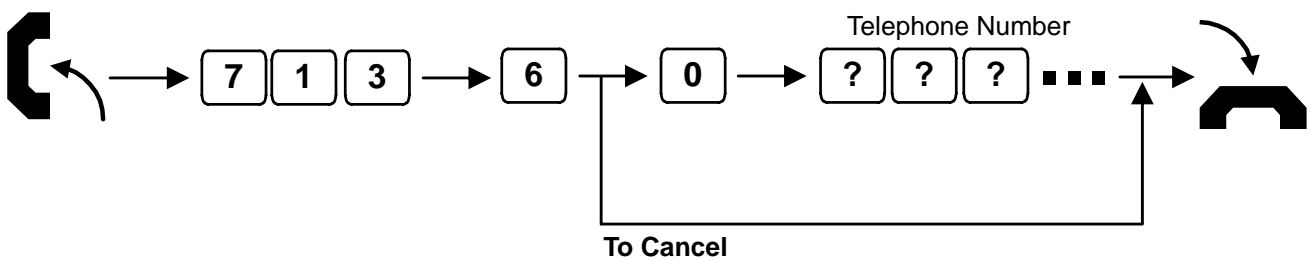

◆ When you set a Call Forward, the DND/CONF Key's lamp flashes and the Internal Dial Tone pattern changes.

# Conferencing

## Establishing a Conference Call

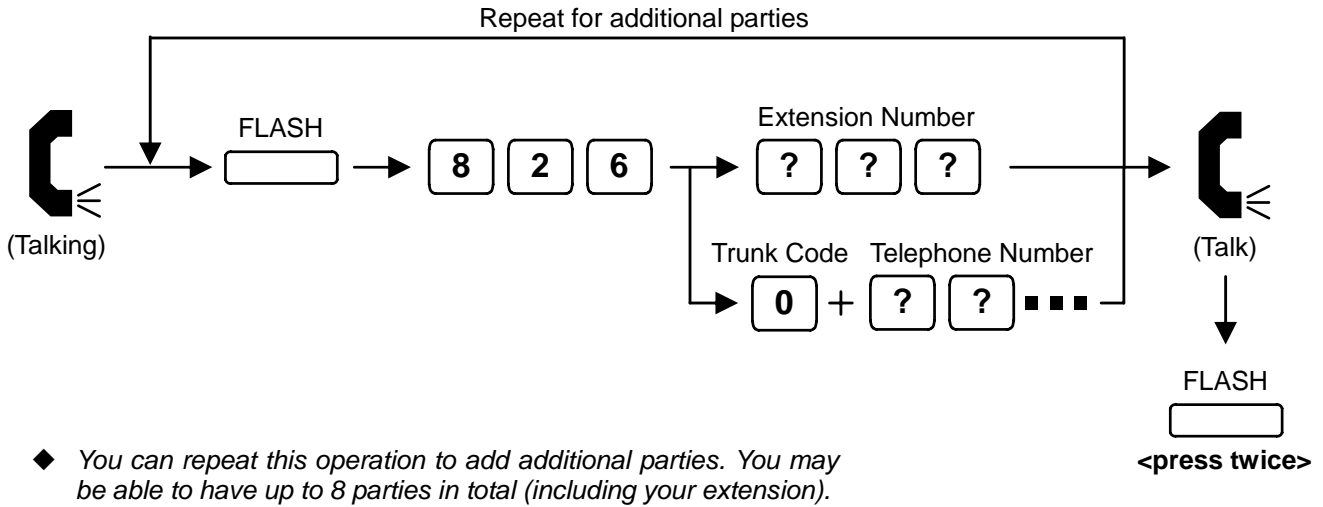

Nothing contained in this manual shall be deemed to be, and this manual does not constitute, a warranty of, or representation with respect to, any of the equipment covered. This manual is subject to change without notice and NEC Business Solutions Ltd has no obligation to provide any updates or corrections to this manual. Further, NEC Business Solutions Ltd also reserves the right, without prior notice, to make changes in equipment design or components as it deems appropriate. No representation is made that this manual is complete or accurate in all respects and NEC Business Solutions Ltd shall not be liable for any errors or omissions. In no event shall NEC Business Solutions Ltd be liable for any incidental or consequential damages in connection with the use of this manual. This document contains proprietary information that is protected by copyright. All rights are reserved. No part of this document may be photocopied or reproduced without prior written consent of NEC Business Solutions Ltd.

Copyright © 2004 by NEC Business Solutions Ltd  
All Rights Reserved.